

Pneumobil Racing Team Brno

Matúš Ranaša

Vysoké Učení Technické Brno
Fakulta Strojního Inženýrství
Ústav konstruování



Kto sme ...

V rámci Ústavu konštruování, funguje tím vyvíjajúci vozidlo poháňané stlačeným vzduchom nazývané Pneumobil. Študenti majú možnosť sa v priebehu štúdia do procesu vývoja vozidla zapojiť, uplatniť tak svoje znalosti a načerpať nové skúsenosti, či už v oblasti konštrukcie a elektroniky alebo pneumatických systémov. Výsledkom je monopost, s ktorým sa každoročne zúčastňujeme medzinárodných závodov.



Ako sme začínali ...

2008 2010 2011 2012 2013 2014 2015 2016 2017 2018 2020

- Vznik súťaže Pneumobilov
- Vznik tímu na VUT
- Prvá účasť na závode
- VUT Monster Trike
- Blowfish
- Medializácia
- Pneumobil Racing Team Brno
- Whirlwind
- Javelin
- Falcon
- Typhoon



Pneumobil Competition

Závody

- Maďarsko, Eger
- 60 týmů
- 8 zemí

Soutěžní kategorie

- Long distance race
- Arcade race
- Acceleration race
- Construction

Podmínky soutěže

- tým max. 6. studentů
- 4 kolové vozidlo (od 2020)
- pohon výhradně stlačeným vzduchem
- pneumatické prvky výhradně od Aventics



www.pneumobil.hu

FALCON

MAXIMÁLNÍ RYCHLOST

52 km/h

MAXIMÁLNÍ DOJEZD

7,2 km

HMOTNOST

92 KG



POHONNÁ JEDNOTKA

Pneumatický válec
ø100 mm, zdvih 500 mm
2-rychlostní převodovka

ROK VÝROBY

2017/18



FALCON

MAXIMÁLNÍ RYCHLOST
52 km/h

MAXIMÁLNÍ DOJEZD
12 km

HMOTNOST
90 Kg

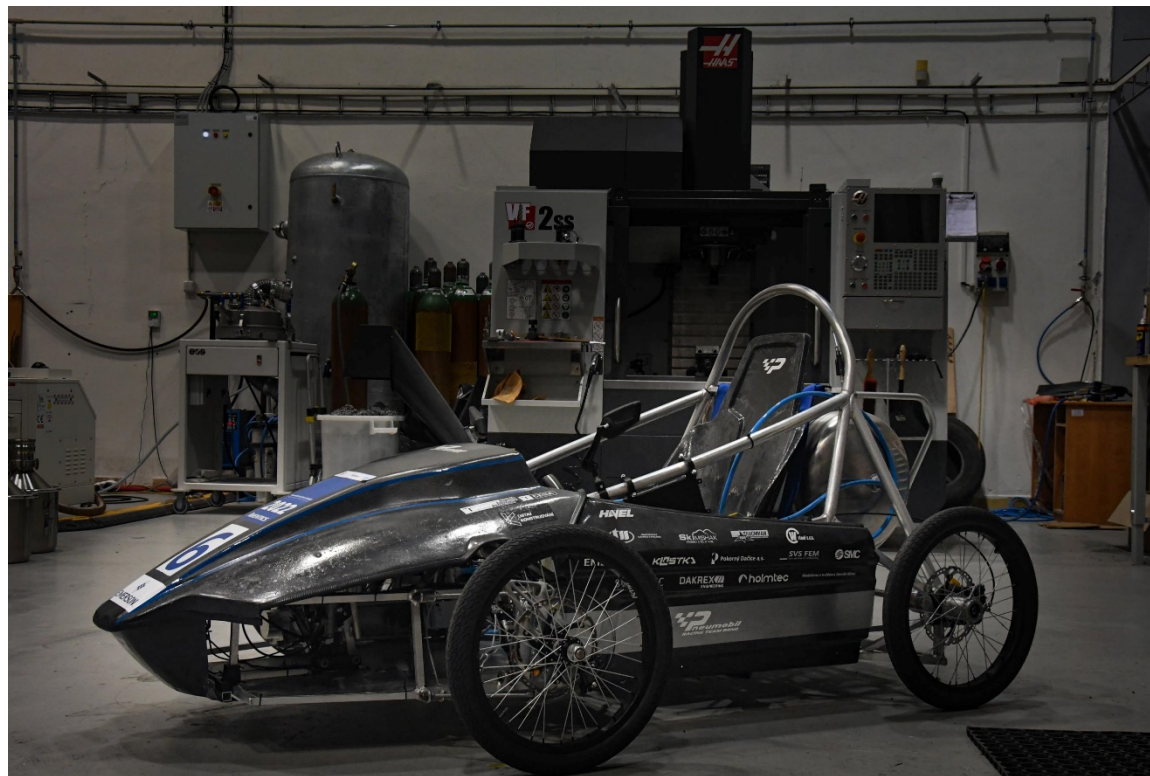

POHONNÁ JEDNOTKA
Pneumatický válec
ø100 mm, zdvih 500 mm
2-rychlostní převodovka

ROK VÝROBY
2021/22



Pneumobil Competition



Javelin	2017	2018	2019
ACCELERATION	7.miesto	8.miesto	6.miesto
TOP SPEED	4.miesto	9.miesto	-
LONG DISTANCE	9. miesto	8.miesto	DNF
ARCADE	7.miesto	3.miesto	DNF
SPECIAL PRICE	-	The best suspension	The best suspension

Falcon	2018	2019
ACCELERATION	1.miesto	7.miesto
TOP SPEED	2.miesto	1.miesto
LONG DISTANCE	4.miesto	7.miesto
ARCADE	DNF	DNF
SPECIAL PRICE	Project Managment	The Fastest Vehicle



Vývoj

G: ZATACENI_PRAVA
Total Deformation 2
Type: Total Deformation
Unit: mm
Time: 2

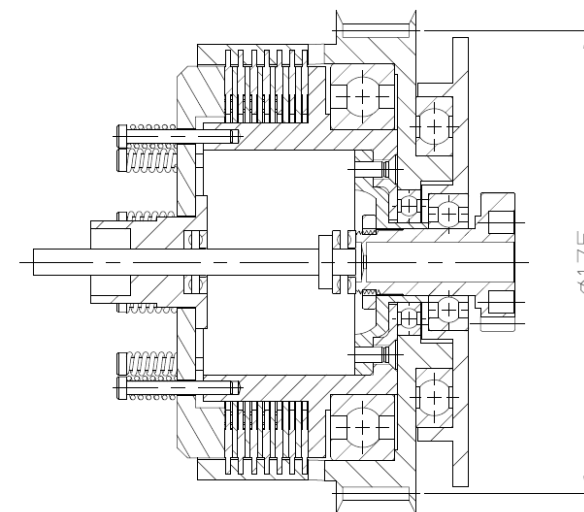
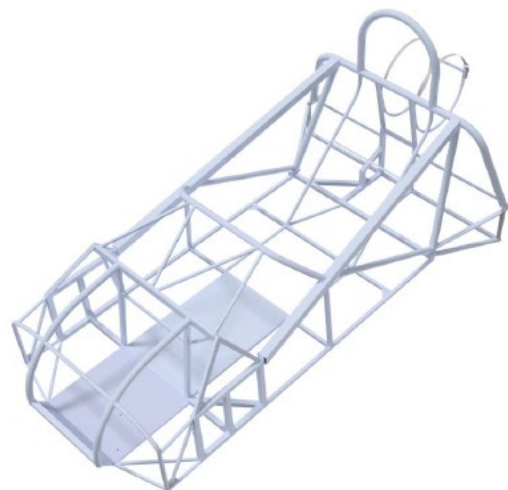
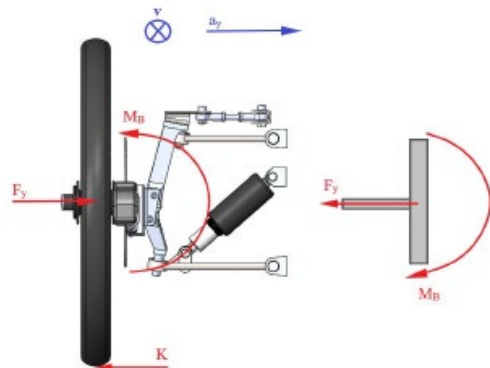
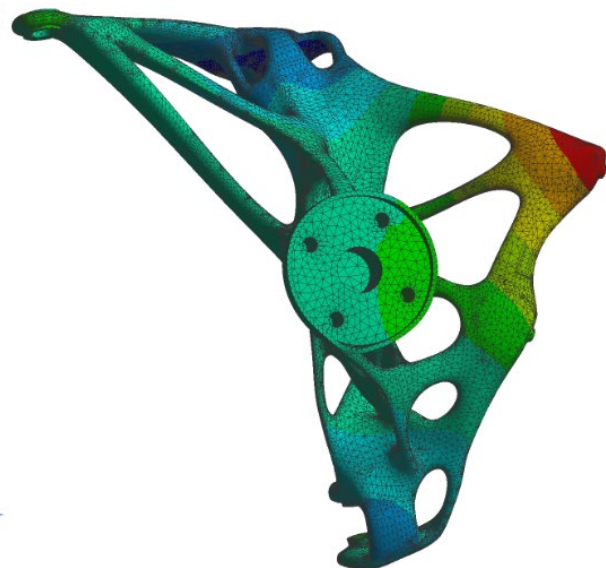
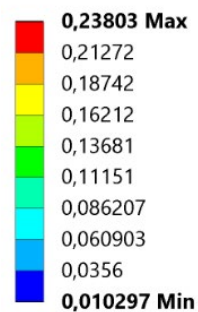

Výroba

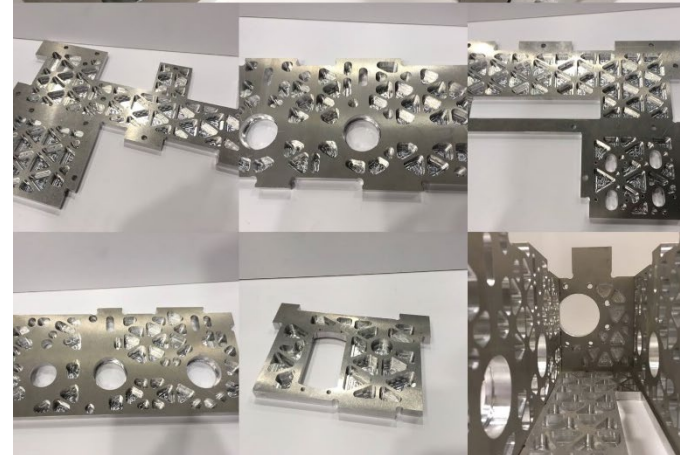
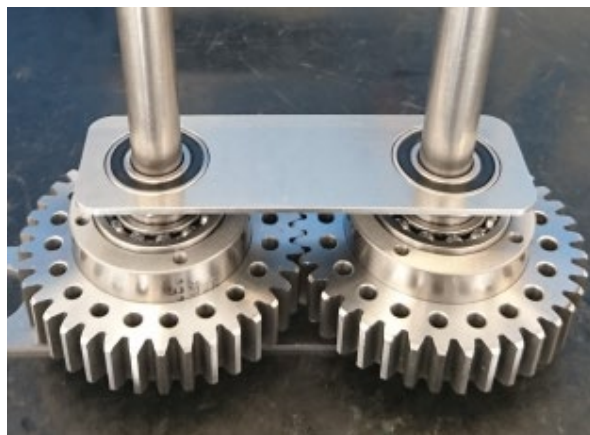
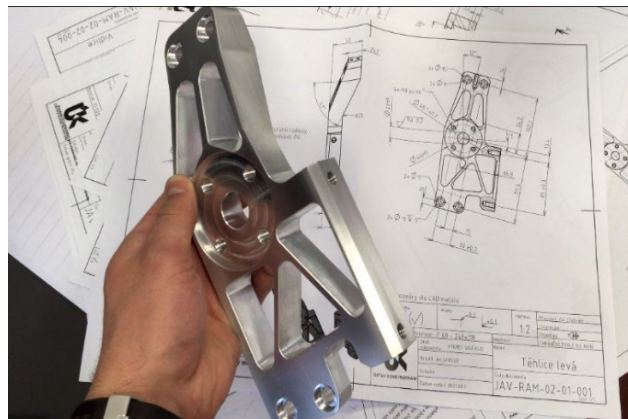
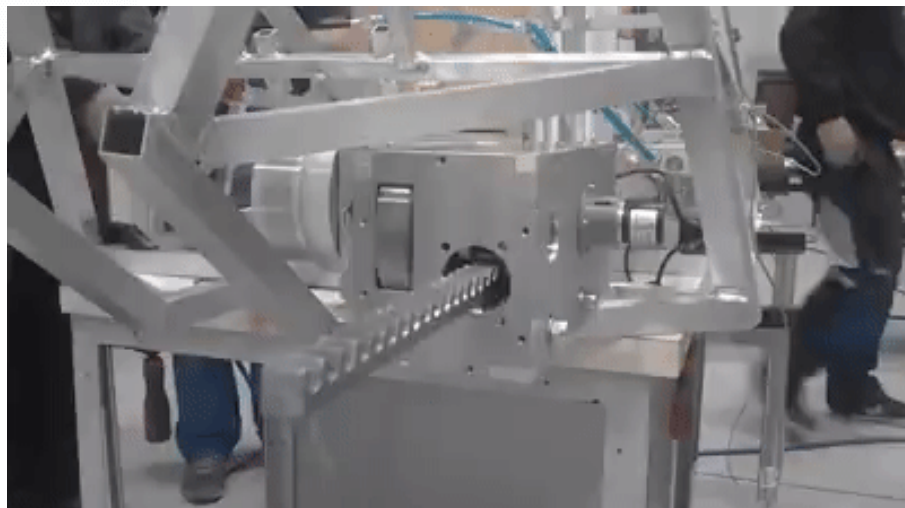

Montáž

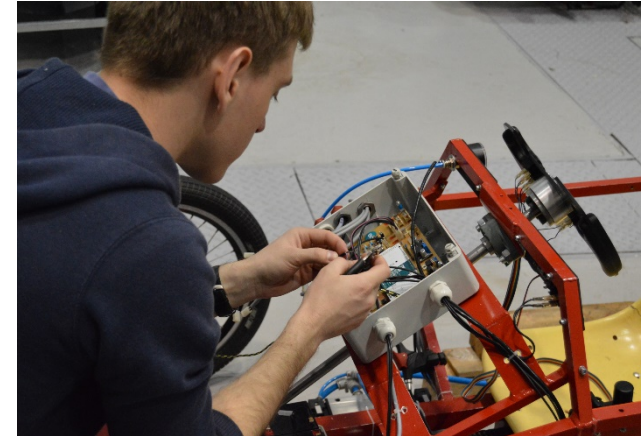
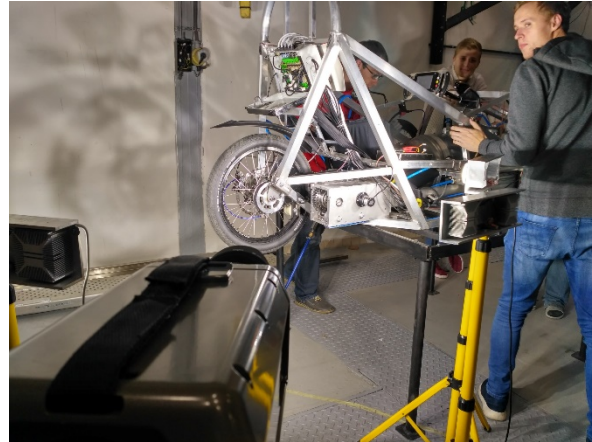

Testovanie

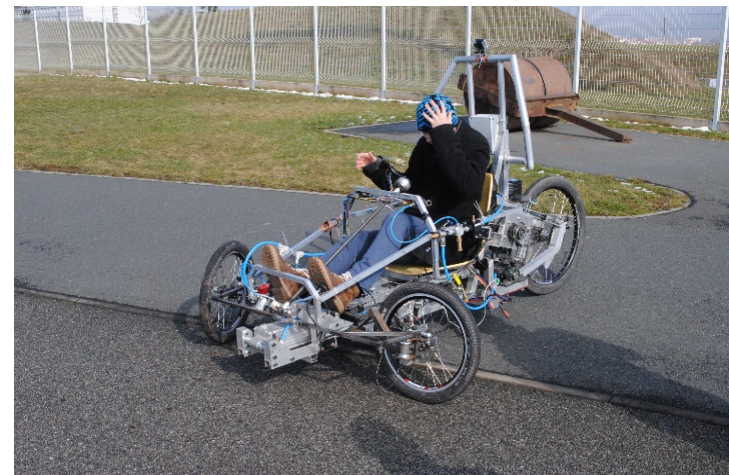
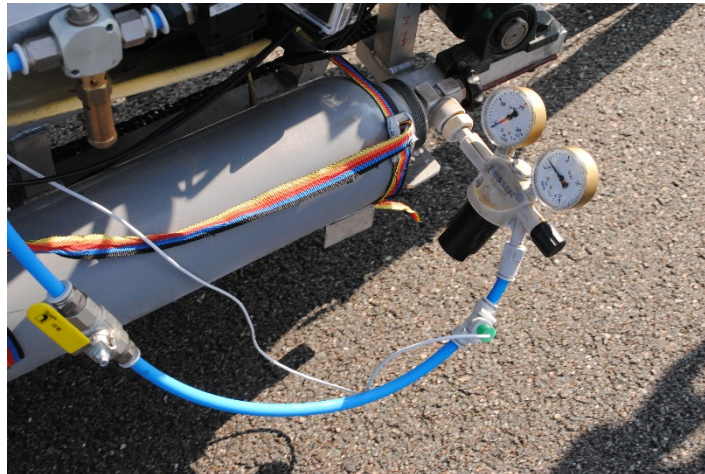

Závody



Postav auto na vzduch a vyhraji!



Expertise – Passion – Automation



strojLAB





PNEURACER

- Středoškolská soutěž
- Navrhnout a postavit dálkově ovládané autíčko na stlačený vzduch
- 3 – 5 členné týmy
- Soutěž:
 - Arcade race
 - Long distance
 - Acceleration race
- Nové zážitky, zkušenosti a věcné ceny, prominutí přijímací zkoušky z matematiky a/nebo fyziky do bakalářského studia FSI



Pravidla

- Max. rozmery 550 (š) x 750 (d) x 350 (v) mm
- Zdroj vzduchu - Tlaková láhev 1l / 10 barů
- Rozpočet 4500 Kč / tým
- Řízení a ovládaní pneuraceru na dálku
- Možnosti využití kitů - elektronika, řízení, konstrukce (v hodnotě 3000 Kč)
- Podpora v oblasti pneumatiky
- Technická podpora VUT – mentor týmu , technické zázemí





Harmonogram soutěže a sponzoři

31. 12. 2023 – ukončení registrace

Do 31. 1. 2024 – představení konceptu

11. 2. 2024 – průběžné hodnocení

Do 15. 3. 2024 – dodání dílů

6. 6. 2024 – HLAVNÍ SOUTĚŽNÍ DEN



strojLAB



Prototyp

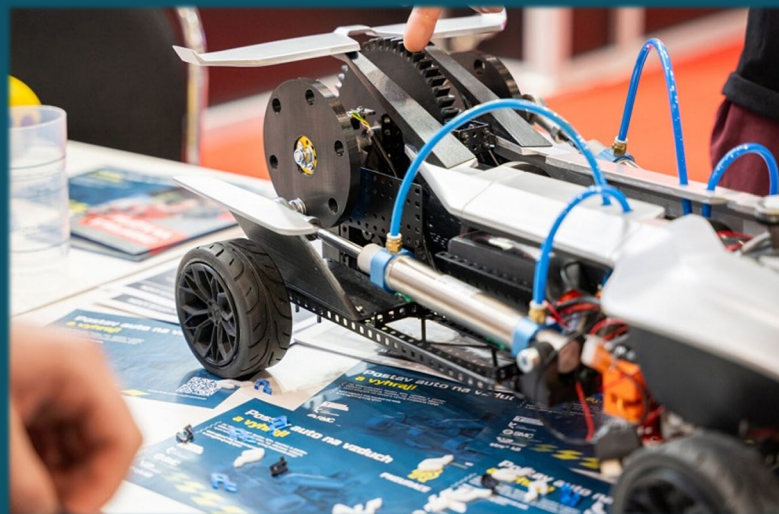
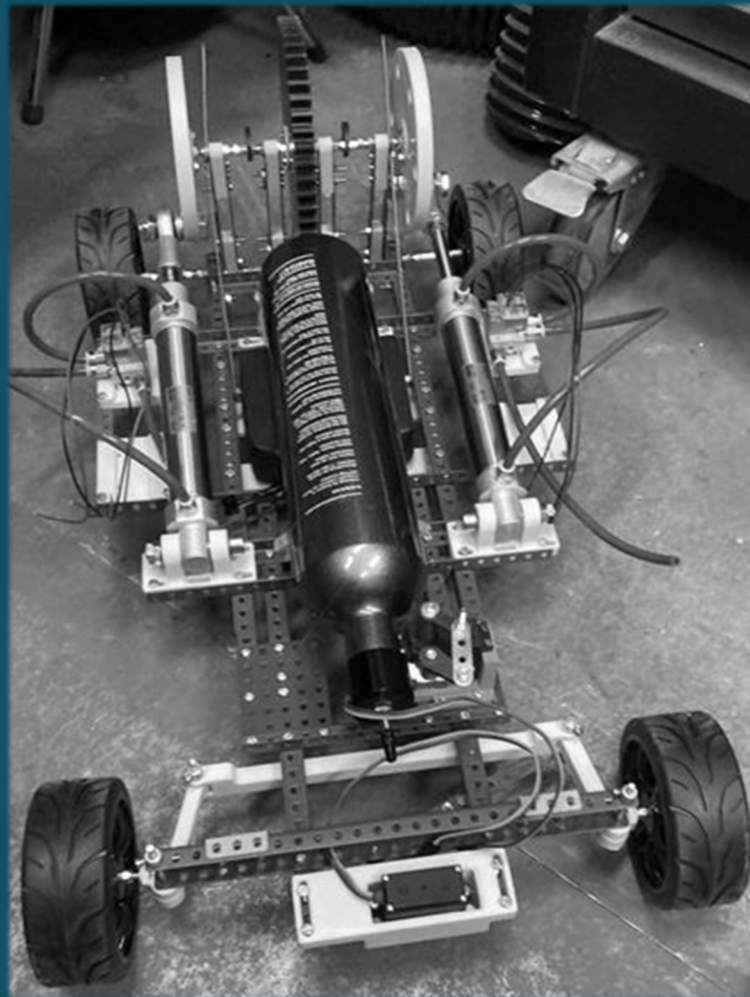



PNEURACER

Ďakujem za pozornosť !

Matus.Ranusa@vut.cz



@PneumobilRacingTeamBrno



@Pneuracer Soutěž



Expertise – Passion – Automation



strojLAB